

AFTC Industrial 5320

PRODUCT INFORMATION 02.2014

1/2

SilverTape 5320

Is a double sided high performance acrylic based adhesive tape, which is especially designed for the bonding of high and medium energy surfaces as well as glass and various transparent plastics where a highly transparent bond is required and no stress corrosion may occur. Due to their conformability they are capable of bonding a variety of different thin and structured materials full surface and tension free. The tape is capable of absorbing the differing thermal expansions of the two different materials. Important is to avoid stress and tension on the bond during application. The 5320 maintains a high impact resistance even at temperatures below 0 °Celsius. More advantages: vibration dampening, very good sealing properties, very good resistance to weathering, aging, yellowing (UV influence), chemicals, plasticizers, resulting in excellent long term stability energy materials.

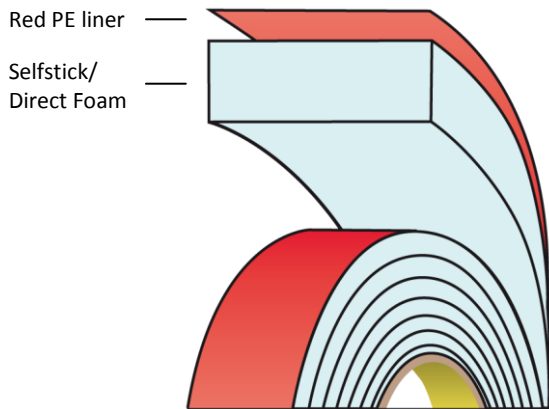

Thickness:	2,0 mm (0.078 inch)
Core:	Closed cell acrylic
Adhesive:	Closed cell acrylic
Density:	900 kg/m ³ (56lb/ft ³)
Color:	Transparent
Liner:	Red PE liner or white paper liner
Solvent Resistance:	Excellent
UV Resistance:	Excellent
Temperature Resistance:	
short term	160°C
long term	100°C

90° Peel Adhesion	N/10mm (lb/in)	37 (21)		ASTM D3330
Dynamic Shear Strength	kPa (lb/in ²)	430 (62)		ASTM D-1002
Normal Tensile	kPa (lb/in ²)	660 (96)		ASTM D-897
Static Shear Strength	grams	22°C (72°F)	1000	ASTM 3654
		66°C (150°F)	500	
		93°C (200°F)	500	
		121°C (250°F)		
		177°C (350°F)		

Suitable for:

- high and medium surface energy plastics, transparent plastics, stainless steel, galvanized, anodized aluminum, coated aluminum, glass*

Available sizes:

- jumbo: 500mm x 165meters (core 3")
- log: 500mm x 16,5/33meters (core 3")
- slit roll: 4 – 250mm x 16,5/33 meters (core 3")
- spool roll: 5 – 25mm x max 600 meters (core 6")

AFTC Industrial 5320

PRODUCT INFORMATION 02.2014

2/2

Manual Production

Every good bond starts with good preparation. This preparation consists of several steps, such as cleaning, use of a primer and the right working area. Please ensure that your workshop area is in a dust free environment and has a minimum room temperature of ca. 15 °Celsius.

Cleaning

Before you begin, always check how dirty the materials that you want to bond are. If they are highly contaminated with oil or grease, clean it with an industrial cleaner (SilverTape® Cleaner) or a heptanes solution. Even when the surface is clean, use our SilverTape® Cleaner, which is a 100% Isopropanol solution. Ensure that you wipe the surface in just one direction, so that the dirt is wiped off. If you do not do this you will always leave some dust or dirt on the substrate.

Quality

The quality of the bond also depends largely on the contact that the two surfaces make with each other. Because of its viscoelasticity, the tape is able to flow into the microscopic pores of the materials. However, if there is a big surface mismatch or if the materials are not pressed together the bond will reach its end strength more slowly, or not at all. Therefore we advise you to put pressure on the bond of at least 100 kPa to allow the tape to make a perfect bond between the two materials.

Maximum Bond

The end strength will be reached much faster if you use our SilverTape® Primer no. 22. This enables the tape to reach its end bond within 5 – 20 minutes instead of taking 72 hours. On making the bond the tape without the primer normally has 50% of its final bond strength and with use of the primer this will be boosted up to 80%. If you have any questions regarding the primer, the manual or the mechanical application, please contact our technical sales team.

Storage & Shelf life

Please make sure that the tape is stored in its original packaging, in a dry place and at a temperature of preferably between 4 °C and 38 °Celsius. When the tape is stored under the right conditions it has a shelf life of 18 months.

*Important Information

All technical data in this product data sheet is based on our own experience and external test institutes. These values are representative and cannot automatically be used for your own specific application. You will first need to test whether the tape is suitable for your application or project. We must point out that you need to follow the rules and regulations that are applicable in the state, county or country that you are using our product in. If you have any questions regarding the use of our acrylic foam tape, please contact our technical service or technical sales team. For questions on the warranty we refer to our delivery terms and conditions, or another warranty document should be agreed on in writing between us and the customer. SilverTape® is a brand name of AFTC.